

CLEANING AND MAINTENANCE

- 1 After use and before cleaning, switch off at the mains, remove the plug from the wall socket and wait for the toaster to cool.
- 2 Wipe the outside of the toaster with a damp cloth only and dry with another cloth or tissue.
 - NEVER use metal polish or coarse scouring agents and never immerse your appliance in any sort of liquid.
 - NEVER use any pointed or sharp articles for cleaning the inside, otherwise the heating element will be damaged.
 - NEVER use a brush or push your fingers or metal objects down the slots.

Crumb tray(s)

WARNING: Crumbs will accumulate in the crumb tray(s) and could catch fire if not emptied regularly.

When the appliance has cooled down completely, tap the sides of the case lightly to dislodge any crumbs lodged in the appliance chamber and remove the crumb tray(s) . Empty the tray(s) and replace.

Never operate the appliance without the crumb tray(s) fitted.

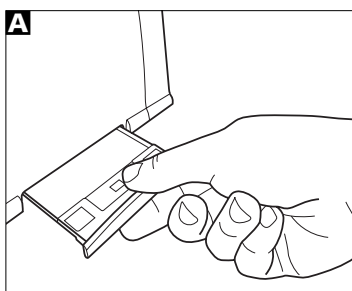

HELPLINE

If you have any difficulty with your appliance, do not hesitate to call us.

We are more likely to be able to help than the store from where you bought it.

Please have the following information ready to enable our staff to deal with your query quickly.

- Name of the product.
- Model number as shown on the underside of the appliance.
- Serial number as shown on underside of the appliance.

UK Helpline 0844 871 0957

Replacement Parts 0844 873 0723

Ireland Helpline 1800 409 119

WEBSITE

You may also contact us through our website, or visit the site to browse and purchase appliances, spare parts and accessories from the extensive Morphy Richards range.

www.morphyrichards.com

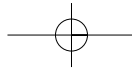

YOUR TWO YEAR GUARANTEE

It is important to retain the retailer's receipt as proof of purchase. Staple your receipt to this back cover for future reference.

Please quote the following information if the product develops a fault. These numbers can be found on the base of the product.

Model no.

Serial no.

All Morphy Richards products are individually tested before leaving the factory. In the unlikely event of any appliance proving to be faulty within 28 days of purchase, it should be returned to the place of purchase for it to be replaced.

If the fault develops after 28 days and within 24 months of original purchase, you should contact the Helpline number quoting model number and serial number on the product, or write to Morphy Richards at the address shown.

You may be asked to return a copy of proof of purchase.

Subject to the exclusions set out below (see Exclusions), the faulty appliance will then be repaired or replaced and dispatched usually within 7 working days of receipt.

If, for any reason, this item is replaced during the 2 year guarantee period, the guarantee on the new item will be calculated from original purchase date. Therefore, it is vital to retain your original till receipt or invoice to indicate the date of initial purchase.

To qualify for the 2 year guarantee, the appliance must have been used according to the instructions supplied. For example, crumb trays should have been emptied regularly.

EXCLUSIONS

Morphy Richards shall not be liable to replace or repair the goods under the terms of the guarantee where:

- 1 The fault has been caused or is attributable to accidental use, misuse, negligent use or used contrary to the manufacturer's recommendations or where the fault has been caused by power surges or damage caused in transit.
- 2 The appliance has been used on a voltage supply other than that stamped on the products.
- 3 Repairs have been attempted by persons other than our service staff (or authorised dealer).
- 4 The appliance has been used for hire purposes or non domestic use.

- 5 The appliance is second hand.
 - 6 Morphy Richards are not liable to carry out any type of servicing work, under the guarantee.
 - 7 Plastic filters for all Morphy Richards kettles and coffee makers are not covered by the guarantee.
 - 8 Batteries and damage from leakage are not covered by the guarantee.
- This guarantee does not confer any rights other than those expressly set out above and does not cover any claims for consequential loss or damage. This guarantee is offered as an additional benefit and does not affect your statutory rights as a consumer.
 - This guarantee is valid in the UK and Ireland only.



For electrical products sold within the European Community. At the end of the electrical products useful life, it should not be disposed of with household waste. Please recycle where facilities exist. Check with your Local Authority or retailer for recycling advice in your country.

morphy richards®

**The After Sales Division
Morphy Richards Ltd**
Mexborough, South Yorkshire,
England, S64 8AJ

Helplines (office hours)
UK 0844 871 0957
Spare Parts 0844 873 0723
Republic of Ireland 1800 409 119

TT44845 MUK Rev 2 09/08

Morphy Richards products are intended for household use only.

Morphy Richards has a policy of continuous improvement in product quality and design. The company, therefore reserves the right to change the specification of its models at any time.

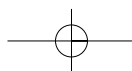

morphy richards®



Accents Die Cast 2 and 4 slice toasters

 Please read and keep these instructions

Getting the best from your new toaster...

Safety first

Do not touch metal top or sides of the appliance during or after use as they get very hot.

Empty crumb tray(s) regularly

To clean away any crumbs that accumulate after use.

In order to achieve uniform browning

Wait a minimum of 30 seconds between each toasting, so that the control can automatically reset.

TT44845 MUK Rev 2



If you have a problem or complaint, please call our dedicated UK based helpline before returning your product to the retailer from where it was purchased.

 UK Helpline: 0844 871 0957
Replacement Parts: 0844 873 0723
Ireland Helpline: 1800 409 119

For details of other Morphy Richards products, plus replacement parts and accessories, please see our website:

www.morphyrichards.com

IMPORTANT SAFETY INSTRUCTIONS

The use of any electrical appliance requires the following common sense safety rules.

Primarily there is danger of injury or death and secondly the danger of damage to the appliance. These are indicated in the text by the following two conventions:

WARNING: Danger to the person!

IMPORTANT: Damage to the appliance!

In addition we offer the following safety advice.

Location

- Always locate your appliance away from the edge of the worktop.
- Ensure that the appliance is used on a firm, flat, heat resistant surface.
- Ensure that sufficient space is left above and around all sides of your appliance to allow air to circulate.
- Do not use the appliance outdoors or near water.
- **IMPORTANT:** Do not use too close to curtains, draperies, walls, cupboards and other flammable materials.
- **WARNING: Do not use underneath cupboards.**

Personal safety

- Do watch your appliance during use.
- **WARNING: Do not touch the top of the appliance or other hot parts during or after use, use handles or knobs.**

- **WARNING: Do not insert oversized foods, metal, foil packages or utensils into the toaster.**
- **WARNING: Do not attempt to dislodge food when the appliance is plugged in and never insert cooking utensils into the slots.**
- **IMPORTANT:** Do not place bread or other items on top of the slots as this may damage the appliance and create a fire hazard.
- This appliance is not intended for use by persons (including children) with reduced physical, sensory or mental capabilities, or lack of experience and knowledge, unless they have been given supervision or instruction concerning use of the appliance by a person responsible for their safety.

Mains lead

- The mains lead should reach from the socket to the appliance without straining the connections.
- Do not let the mains lead hang over the edge of the worktop where a child could reach it.
- Do not let the lead run across an open space e.g. between a low socket and table.
- Do not let the lead run across a cooker or hot area which might damage the cable.
- If the supply cord is damaged, it must be replaced by the manufacturer, it's service agent, or similarly qualified persons in order to avoid a hazard.

Children

- Never allow a child to operate this appliance.
- Children are vulnerable in the kitchen, particularly when unsupervised and if appliances are being used or cooking is being carried out.
- Teach children to be aware of dangers in the kitchen, warn them of the dangers of reaching up to areas where they cannot see properly or should not be reaching.
- Children should be supervised to ensure that they do not play with the appliance.

Other safety considerations

- Do not operate with a damaged cord or plug or after the appliance malfunctions or has been damaged in any manner. Contact Morphy Richards for advice.
- Do not attempt repairs - the appliance contains no user-serviceable parts. Call our helpline for advice.
- Do not use accessories not recommended by the manufacturer.
- Do not place on or near a hot gas electric burner or in a heated oven.
- Only use for the intended purpose.
- Unplug from the outlet when not in use and when cleaning.
- Do not move the appliance whilst hot.
- The bread may burn, therefore do not use the appliance near or below combustible material such as curtains.

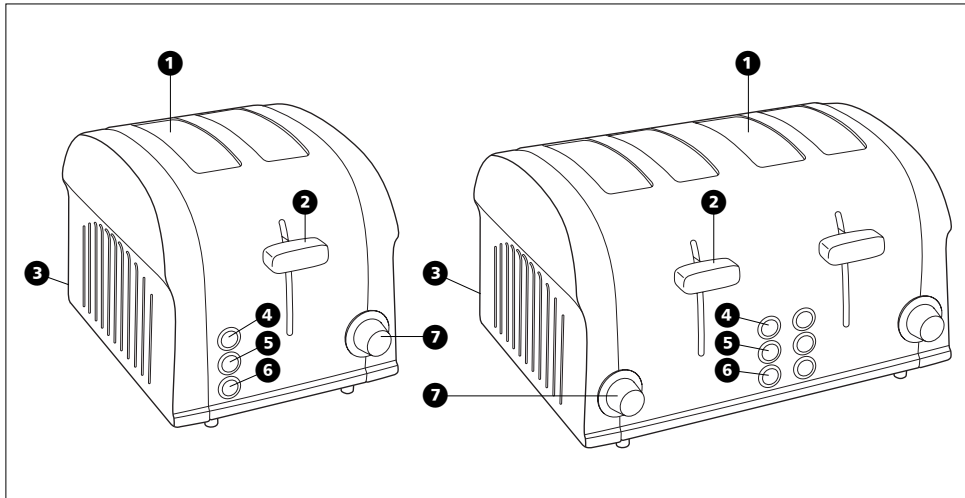

- The appliance is not intended to be operated by means of an external timer or separate remote control system.

ELECTRICAL REQUIREMENTS

Check that the voltage on the rating plate of your appliance corresponds with your house electricity supply which must be A.C. (Alternating Current).

If the socket outlets in your home are not suitable for the plug supplied with this appliance, the plug should be removed and the appropriate one fitted.

WARNING: The plug removed from the mains lead, if severed, must be destroyed, as a plug with a bared flexible cord is hazardous if engaged into a live socket outlet.

Should the fuse in the 13 amp plug require changing, a 13 amp BS1362 fuse must be fitted.

WARNING: This appliance must be earthed.

FEATURES

- Bread slots
- Bread carriage lever with high lift feature
- Removable crumb tray(s) at rear
- Cancel button
- Reheat button
- Frozen button
- Electronic variable browning control

Key

-  Frozen button
-  Re-heat button
-  Cancel button
-  High lift feature

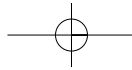

BEFORE FIRST USE

- Before using the toaster for the first time, operate the toaster without bread.

Note: The bread carriage lever(s) ② will not stay down unless the toaster is plugged in and the wall switch is on. Ventilate the room during this process.

- As with all new electric heating elements, your toaster emits a 'new' smell when it is first switched on. This is quite normal and not a cause for concern.

OPERATING THE APPLIANCE

On the four slice models, the toaster has two sides with controls repeated for each half. Each half can be used together or independently.

- 1 Select the desired level of browning on the browning control dial ⑦.
- 2 After selecting the desired level, place your bread in the slots ① and depress the bread carriage lever downwards until it locks.
- 3 After the set time has been reached, the bread will pop up automatically - ready for removal from the slots. The bread carriage lever will have returned to its upper position and the heating element will have switched off.

WARNING: Do not wrap the cable around the main body of the appliance during or after use.

ADDITIONAL FEATURES

Using the re-heat button



If your toast has popped up and gone cold, the toaster offers a re-heat facility. To use, depress the relevant bread carriage lever and press the re-heat button ⑤ immediately. The button will illuminate and the toaster will operate for a short period re-heating the bread.

Using the frozen button



To toast frozen bread, do not adjust the browning control from your normal setting. Place the bread in the bread slots as normal, and press the frozen button ⑥.

Cancel button



If you wish to interrupt the toasting cycle, press the Cancel button ④.

Hints and tips

- In order to achieve uniform browning, we recommend you wait a minimum of 30 seconds between each toasting, so that the control can be automatically reset.
- If toasting one slice only, you may need to adjust the browning control to a slightly lower setting.
- Please note: you will also notice a slight variation in toast colour on one side of a single slice.
- Stale bread toasts more rapidly than fresh bread. Therefore, the browning control should be set at a lower setting than usual.
- All sorts of bread can be used, as well as teacakes, small rolls etc. However, slices should not be so thick as to cause burning or jamming within the bread slots.
- If the bread in your toaster becomes jammed, disconnect your toaster at the socket, allow it to cool, then remove the bread.
- When toasting two or more slices, it is recommended they are of equal size and freshness.
- Allow the toaster to cool fully before putting away.

